





Alcor LED Stadium Light

Alcor LED stadium lights are designed to replace 400w to 2000w Metal Halide and HPS stadium lights. Replace your old outdoor area lights, ballpark or stadium lights with a high efficiency LED area light. Save money and replace bulbs less often with a 100,000 hours rated LED. Fixture is also ideal for new installations.

Alcor LED Stadium Light



Features:

- High impact resistance IK10
- High protection level up to IP66
- Anti 17-level wind power
- High vibration resistance
- Surge suppression protection
- Intelligent control
- Extraordinary thermal management

Materials:

- Body: Aluminum
- Cover: PC

Options:

- 1-10V
- DALL

Colors:

- Black

Accessory:

Brackets



Item Code	Description							
	Power w	Voltage vac	Frequency hz	Lumen Flux lm	Color Temp k	CRI ra	Operating c°	Warranty yrs
SAS-A500W	500	85-265	50/60	70000±5%	ww nw cw	80	-40 ~ +50	5
SAS-A600W	600	85-265	50/60	84000±5%	ww nw cw	80	-40 ~ +50	5
SAS-A1000W	1000	85-265	50/60	140000±5%	ww nw cw	80	-40 ~ +50	5
SAS-A1200W	1200	85-265	50/60	168000±5%	ww nw cw	80	-40 ~ +50	5

Alcor LED Stadium Light

Light distributions:

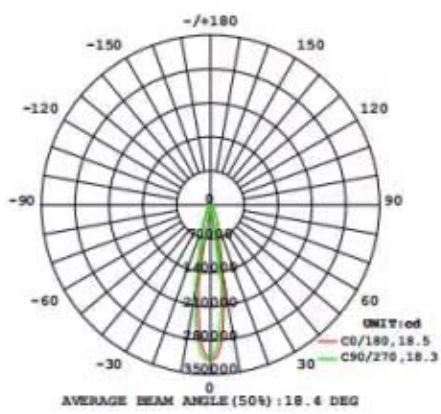

10°

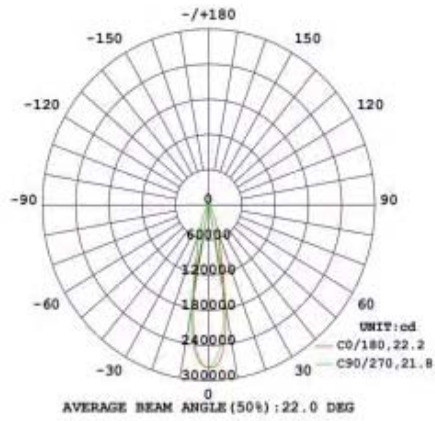

25°

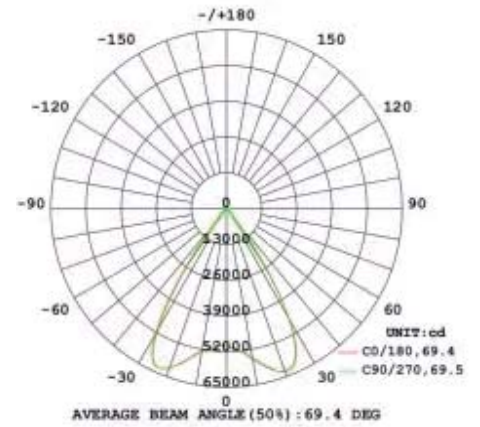

60°

Dimensions (unit mm)

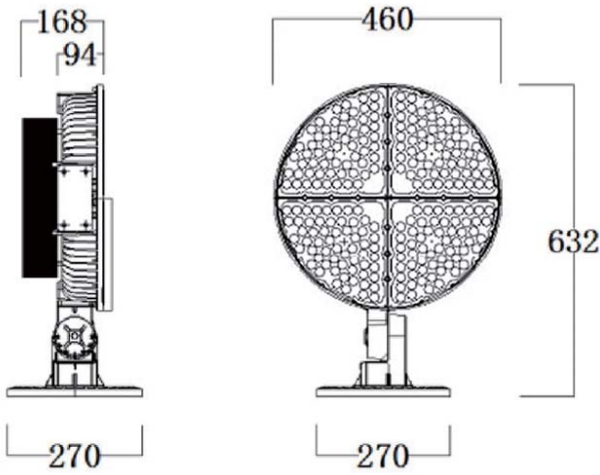

500w/600w

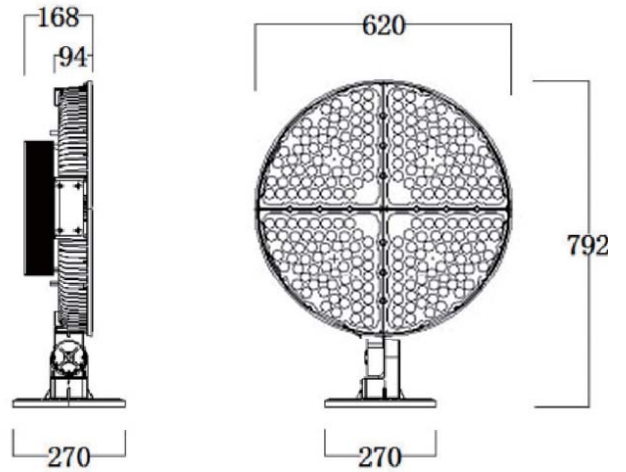

1000w/1200w