





## Jupiter LED Flood Light

This Jupiter large outdoor LED flood light is good for illuminating areas that require a lot of light. It is heavy duty, slim designed and light weight. But can hold up to high winds and severe weather. Swivel mount option allows you to pole mount or surface mount on buildings.

# Jupiter LED Flood Light



### Features:

- Narrow Beam Angle: 8°/15°/35°/60°/90°
- Durable tempered glass front
- Integrated design of driver box
- 270 degree adjustable brackets
- Ultra slim elegance housing design
- Industrial silicone gasket assuring IP65 grade
- Long life time, rated for over 55,000hrs

### Materials:

- Body: Aluminum-Alloy Die Casting
- Cover: Tempered glass

### Options:

- 1-10V
- DALI

### Colors:

- Black

### Accessory:



Bracket



Item Code	Description							
	Power w	Voltage vac	Frequency hz	Lumen Flux lm	Color Temp k	CRI ra	Operating c°	Warranty yrs
FP-B50W	50	85-265	50/60	5500±5%	ww nw cw	80	-20 ~ +50	5
FP-B80W	80	85-265	50/60	8800±5%	ww nw cw	80	-20 ~ +50	5
FP-B100W	100	85-265	50/60	11000±5%	ww nw cw	80	-20 ~ +50	5
FP-B150W	150	85-265	50/60	16500±5%	ww nw cw	80	-20 ~ +50	5
FP-B200W	200	85-265	50/60	22000±5%	ww nw cw	80	-20 ~ +50	5

# Jupiter LED Flood Light

## Light distributions:

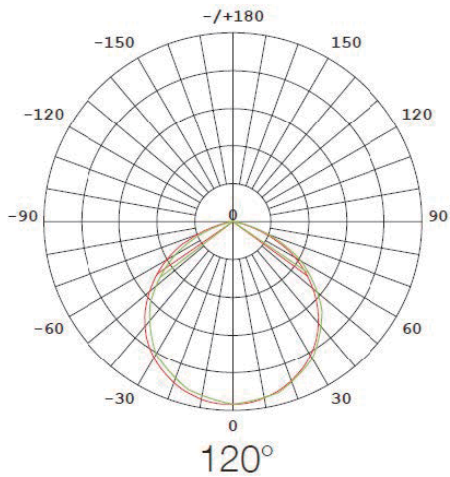

## Lamp illumination:

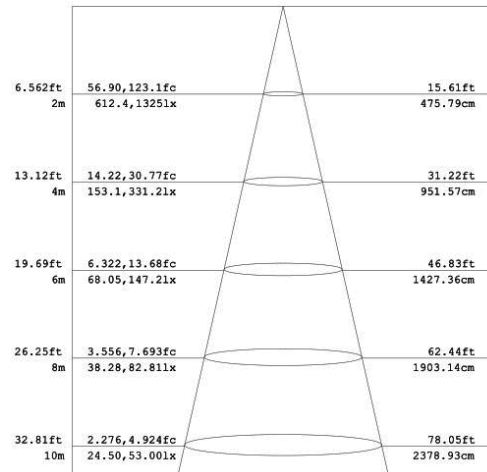

## Dimensions (unit mm)

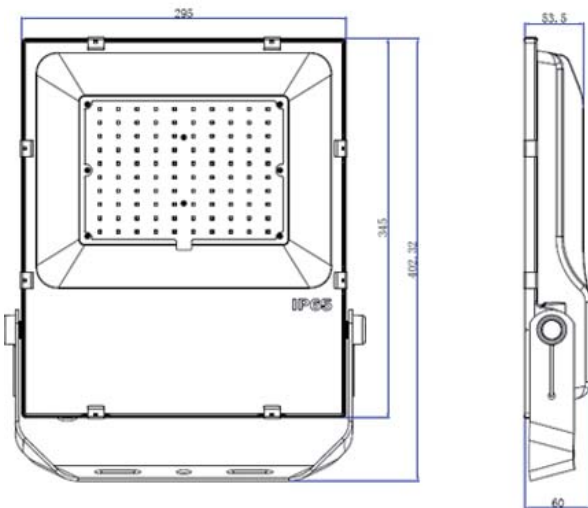

100w

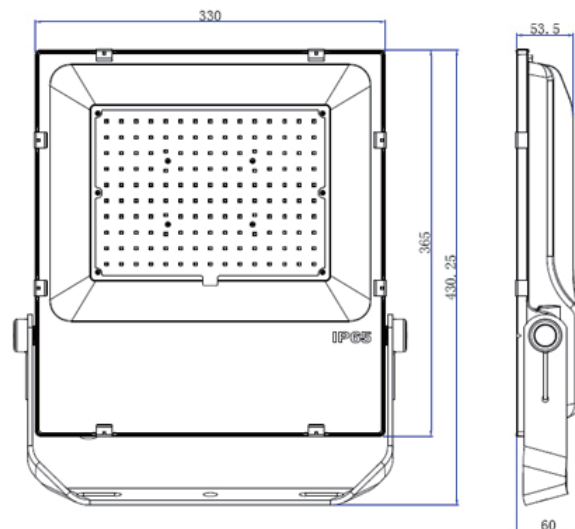

150w

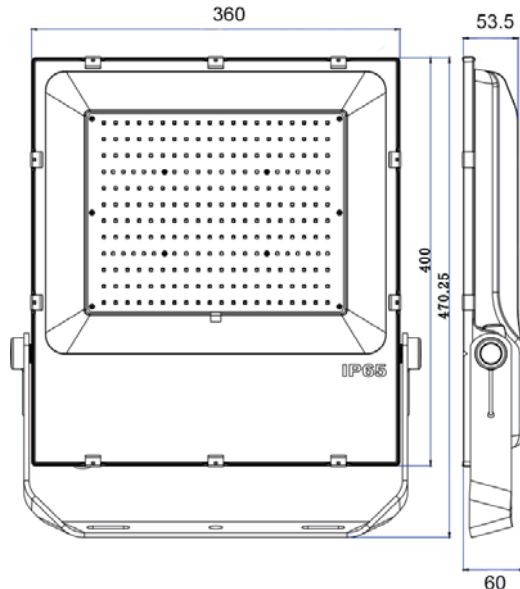

200w